

**Installation Instruction
ESD-6116-AU-1/13**

**Raychem
Joint for 36kV 3 Core
XLPE Insulated Cables
With Integrated Fibre Optic
Cable and Composite
Sheath**

150 - 300mm²

ENDORSED BY	SIGNATURE	DATE
Wilfred Leung Principal Engineer - Mains RailCorp	<i>W. Leung</i>	9. 1. 2013

APPROVED BY	SIGNATURE	DATE
^{REV} Neal Hook Chief Engineer - Electrical RailCorp	<i>W. Leung</i>	9. 1. 2013

APPROVED BY	SIGNATURE	DATE
Andrew Thompson Product Manager TE Connectivity	<i>A. Thompson</i>	9/1/2013

Tyco Electronics Raychem GmbH
Energy Division
Finsinger Feld 1
85521 Ottobrunn/Germany
0049-89-6089-0 tel
0049-89-6089-345 fax
<http://energy.tycoelectronics.com>

Superseded by PTA EL225 2020 v1.0

Check List Number: CL1557-1/13

MXSU-RCP20

Qty: 1

Kit Contents

1	x	EPPA-043-3-5000	Adhesive Textile Tape
6	x	S1189-1-150	Void Filling Mastic 150 Long
3	x	BSMB-120/300	Mechanical Shear Bolt Connector
3	x	EPPA-048	Clay Pack
3	x	S1189-3-600	Void Filling Mastic 600 Long
3	x	JCSR-60/24-430-35/U	Stress Control Tubing 430 Long (1)
3	x	ERIH-65/26-430/U	Screened Insulating Sleeve 430 Long (2)
2	x	WCSM-34/8-1200/S	Fibre Insulating Sleeve 1200 Long Coated
6	x	EPPA-009-5000	Tinned Copper Mesh - 5000 Long
3	x	HEL-4892	Mechanical Shear Bolt Screen Connector
1	x	WCSM-160/50-900/S	First Sealing Sleeve - Coated (3)
4	x	S1061-8-400	Mastic Sealant Black Long - 400 Long
4	x	S1061-8-100	Mastic Sealant Black Short - 100 Long
2	x	BOCL-20-1064C004	Branch Clip - Fibre Optic
2	x	CT5507W	Cable Tie - 500 Long
2	x	WCSM-180/50-625/S	Second Sealing Sleeve - Coated (4)
2	x	102L022/S(S100)	Mastic Lined End Cap
1	x	FOSC-500AA-S24-LT-NN	Fibre Optic Splice Closure
1	x	ESD-6116-AU-1/13	Installation Instruction
1	x	ESD-1573-AU	Check List

TE Connectivity
 TE Energy
 Tyco Electronics Energy Pty Ltd
 ABN 56 000 129 573
 Unit 2, No 3 Corella Close
 Berkeley Vale NSW 2261

02 4389 6000 tel
www.energy.te.com

ESD-1573-AU
 Page : 1 of 1



Before Starting

Check to ensure that the kit you are going to use fits the cable.

Refer to the kit label and the title of the installation instruction.

Components or working steps may have been improved since you last installed this product.

Carefully read and follow the steps in the installation instruction.

General Instructions

Use a propane (preferred) or butane gas torch.

Ensure the torch is always used in a well-ventilated environment.

Adjust the torch to obtain a soft blue flame with a yellow tip.

Pencil-like blue flames should be avoided.

Keep the torch aimed in the shrink direction to preheat the material.

Keep the flame moving continuously to avoid scorching the material.

Clean and degrease all parts that will come into contact with adhesive.

If a solvent is used follow the manufacturer's handling instructions.

Tubing should be cut smoothly with a sharp knife leaving no jagged edges.

Start shrinking the tubing at the position recommended in the instruction.

Ensure that the tubing is shrunk smoothly all around before continuing along the cable.

Tubing should be smooth and wrinkle free with inner components clearly defined.

The Information contained in these installation instructions is for use only by installers trained to make electrical power installations and is intended to describe the correct method of installation for this product. However, Tyco Electronics has no control over the field conditions which influence product installation.

It is the user's responsibility to determine the suitability of the installation method in the user's field conditions. Tyco Electronics' only obligations are those in Tyco Electronics' standard Conditions of Sale for this product and in no case will Tyco Electronics be liable for any other incidental, indirect or consequential damages arising from the use or misuse of the products.

Raychem is a trade mark.

Application range of the MXSU Kits:

The kit is based on polymeric insulated cables for **stranded circular conductors** and wire shielding. Application range for aluminium or copper conductors are mentioned in **Table A** below

Table A

36kV	
Kit Number	Range (mm ²)
MXSU-RCP20	150 - 300

Table B Admissible cable dimensions

	Conductor Ø		Core Insulation Ø	
	min	max	min	max
Kit Number	mm	mm	mm	mm
MXSU-RCP20	13.9	21.6	30.8	39.6

Cable Overlap

Overlap the cables to be jointed to the dimensions shown in drawing & mark the reference line. Slide one sealing sleeve over the long cable end. Fold and tape it down temporarily & position the second sleeve over the first. Slide the third sealing sleeve over the short cable end.

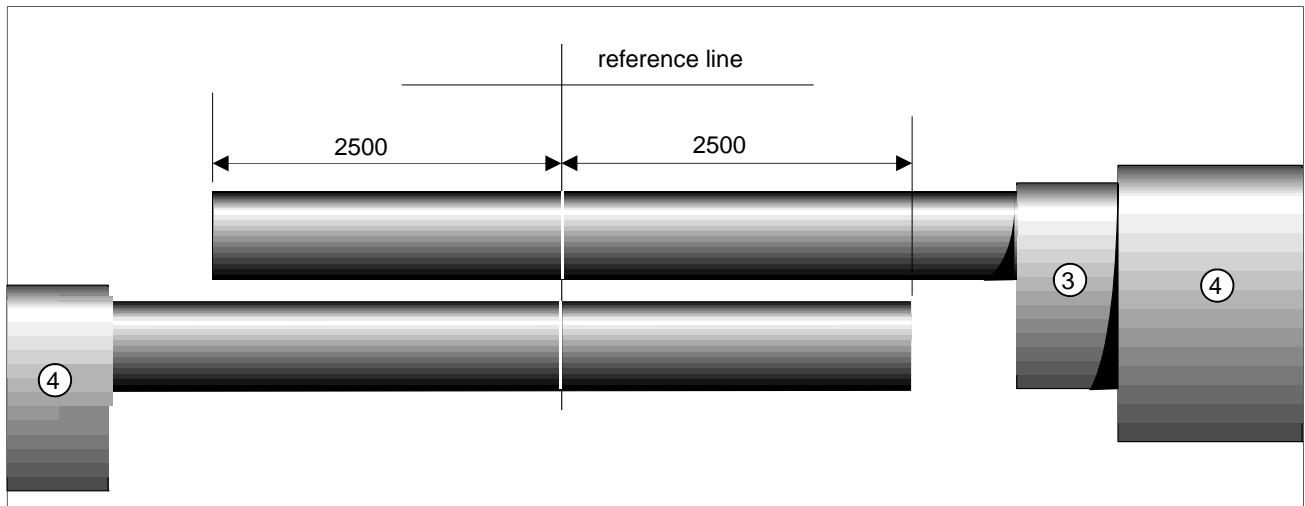

Cable Preparation

Remove the oversheath and inner sheath to the dimensions a, b and d given in **Table 1**.

Lay the fibre optic back onto the oversheath, taking care not to exceed the minimum bending radius. Fix the tube to the oversheath with adhesive tape.

Gather the shield wires together on each core, to form three earth conductors, and fold them back onto the cable oversheath.

Shape and position the cores as shown in drawing A. Cut the cores at the reference line.

Thoroughly remove the core screen according to the dimension c given in **Table 1**, so that the insulation surface is free from all traces of conductive material.

Note: Do not nick the insulation.

Drawing A.

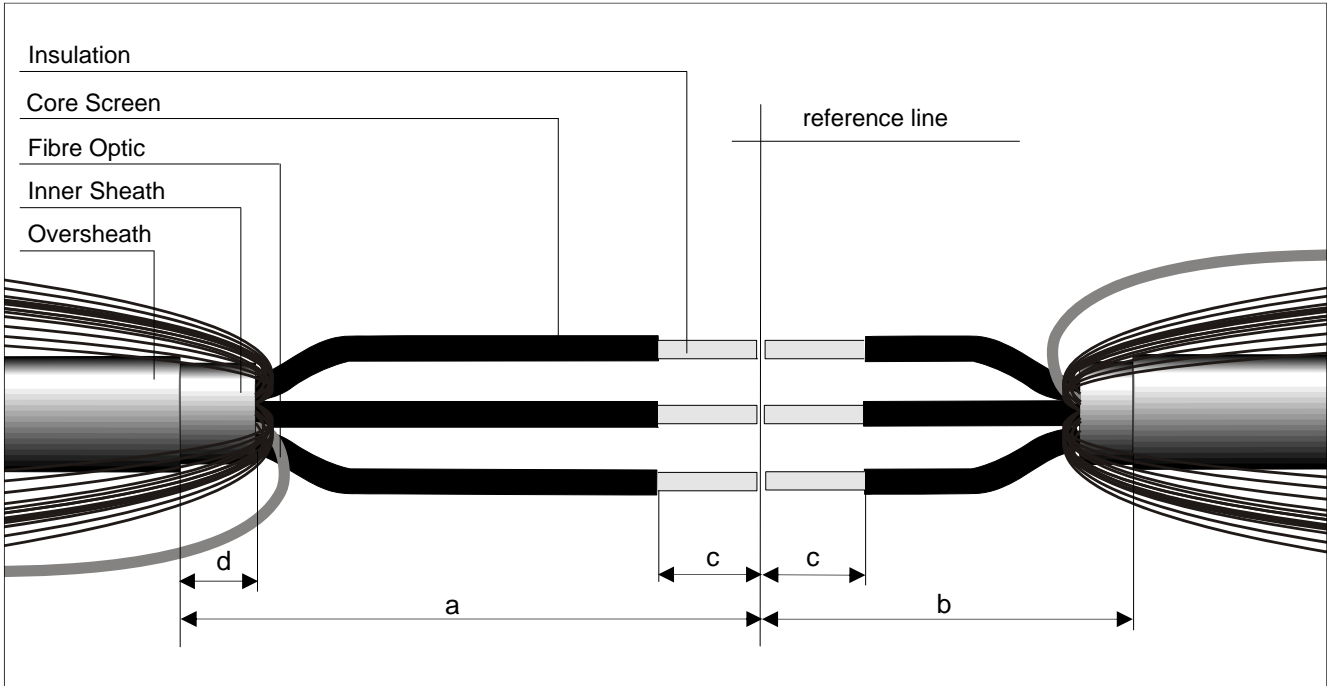
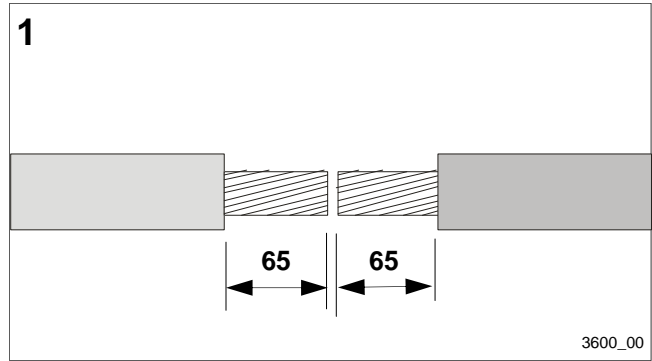

Table 1 **36kV**

Kit range mm ²	a	b	c	d
150 - 300	900	400	170	50

Remove the insulation on all cores for a distance of 65mm.



Take the yellow void filling strip from the aluminium foil pocket. Remove the release papers from the strip with the pointed ends. Wrap the void filler around the core screen starting 20 mm from the end of the screen and continue onto the insulation for 10 mm. Stretch the strip to half of its original width to achieve a fine thin edge.

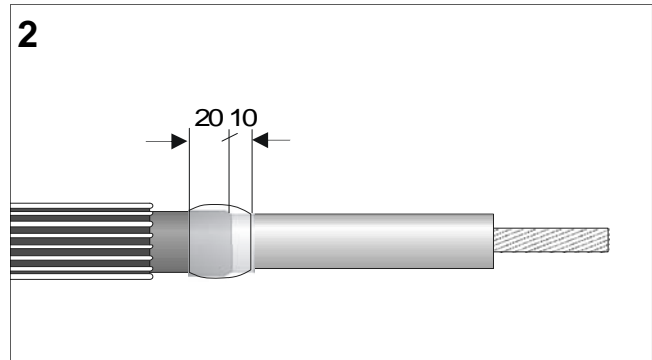

Slide a combined tubing set over each core of the long side of the joint. The plastic bag of the tubing can be used as additional protection by placing it under the tubing set on each core.

1. Stress control tubing (black)
2. Screened/Insulating sleeve (black & red)

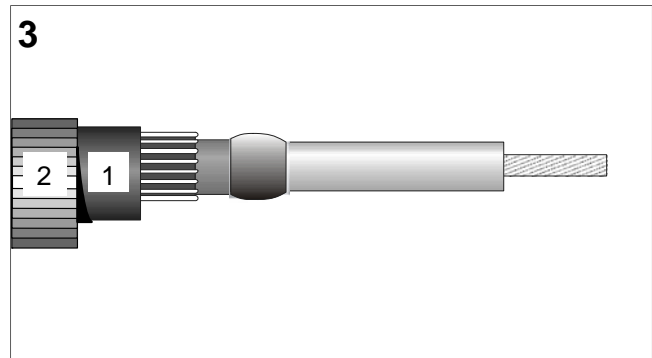

The connector is supplied with insert half shells which have to be used on small cross sections. Check before installation if the conductor can be inserted into the connector with the half shells installed. In case the conductor can not be inserted, remove the inserts from the connector bore.

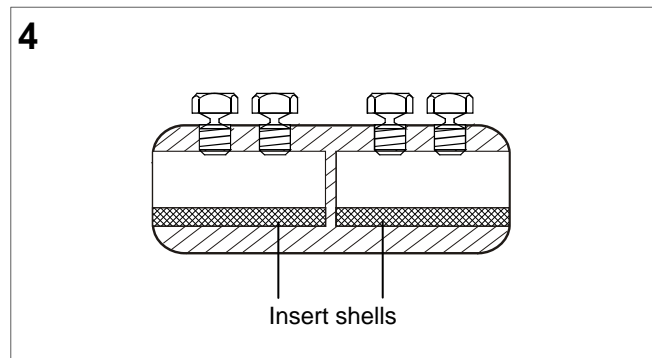

Clean and abrade the surface of the exposed conductors.

Insert conductors so that the insulation butts up with the end of the connector. Hand tighten the shear bolts so that the connector stays in place.

For connectors using more than one shear bolt per side, tighten the bolts alternately and shear them off starting with the outer bolts (see also sequence shown in the drawing).

Notes:

- When a cordless impact wrench is in use the tightening intervals should be in the range of 2 seconds.
- Avoid core bending on smaller cross sections by using a support tool available such as IT-1000-019 or similar.

Smooth out any sharp edges of protruding bolts where appropriate. Clean and degrease the connector area and the insulation with a cleaning wipe.

It could be possible that the bolt shears but the top is retained in the connector body. In that case unscrew the head of the bolt until it is removed from the connector.

Clean and degrease the cable cores and the connector. Fill Raychem clay over the sheared off bolts to obtain a smooth finish.

Take the yellow void filling tape from the alu foil packet. Remove one release paper from the strip & roll up. Apply the tape with 50% overlap stretching it to about half its original width.

Fill up the connector area continuing onto the insulation for not more than 5 mm. Use the filler tape to achieve a smooth transition from the connector onto the insulation.

Note: Do not use too much void filling tape

Position the stress control tubing (1) centrally over the connectors. Start shrinking in the centre working towards the ends. The tubing should be fully shrunk & wrinkle free.

Note: Take care not to accidentally shrink the parked tubing at this stage.

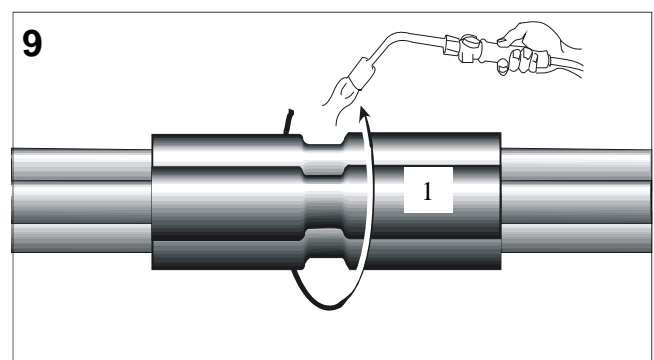
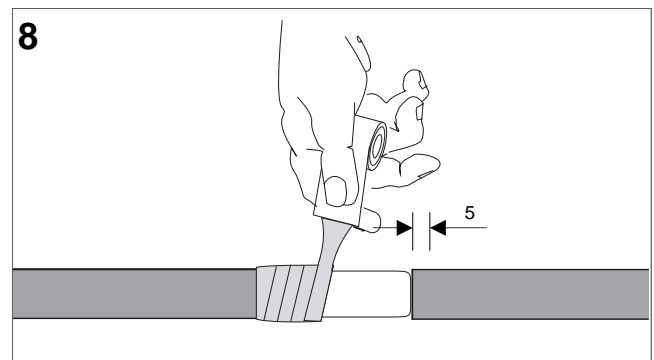
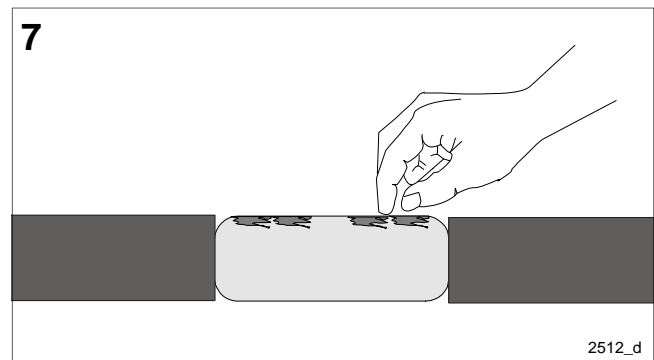
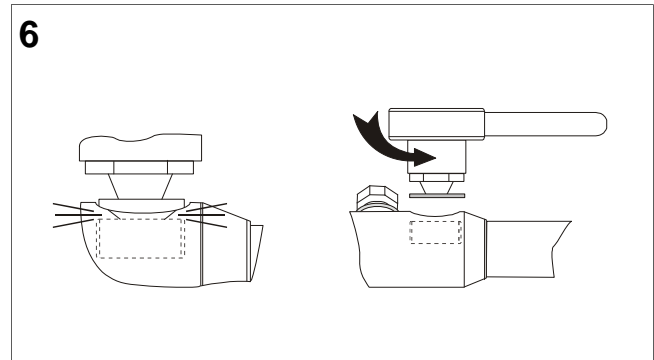
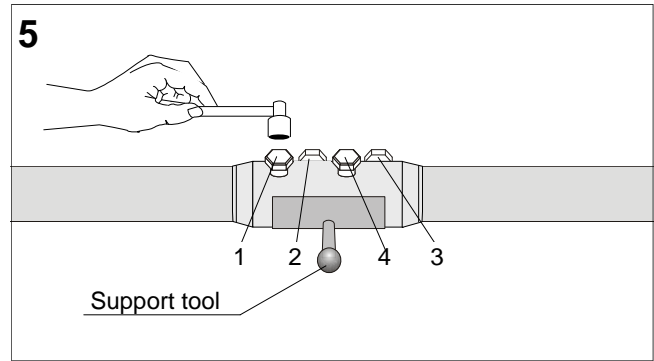

Position the screened insulating sleeves (2) centrally over the stress control tubing.

- a. Start shrinking the sleeves in the centre (1).
- b. Check if fully shrunk by twisting the end. The sleeves should not move from its position.
- c. Continue shrinking by working towards one side (2), stopping 50 mm from the end.
- d. Shrink the other half in the same way (3).
- e. Shrink down the first end (4) and finally the second (5). The sleeves should be fully shrunk without leaving ridges.

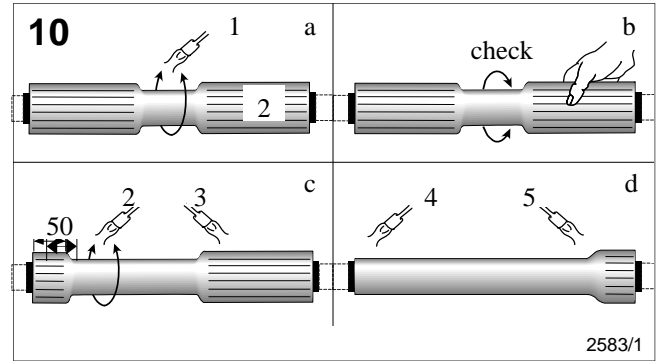

Lay the fibre optic back across the joint.
Note: Screen wires have been omitted for clarity.

Slide the fibre insulating sleeves (black) over the end of the fibre optic tubes. Position them 300mm in from the over sheath on both sides of the joint. Shrink tubing in place for entire length.

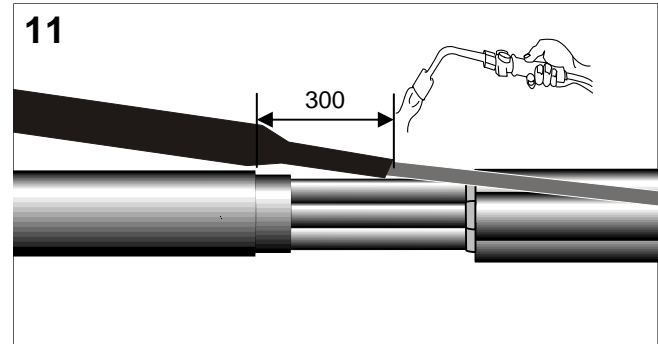

Relay the cores as far as possible.

Wrap one layer of copper mesh, with 50% overlap across the joint.

Allow the blown tube to exit through the mesh on the applicable side.

Fold back the shield wires across the joint and connect using the mechanical connectors. Tighten the bolts until the heads shear off.

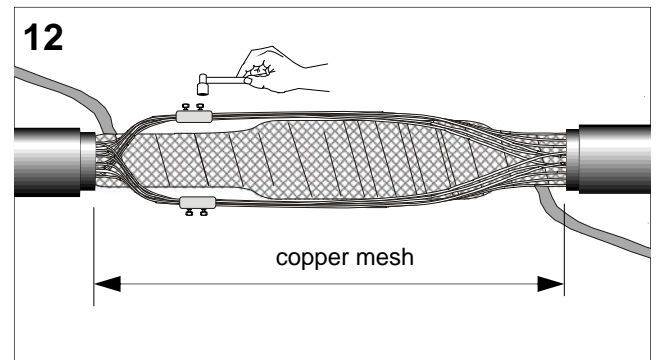

Wrap a second layer of copper mesh round the cores, with a 50% overlap across the joint.

Allow the blown tube to exit through the mesh on the applicable side.

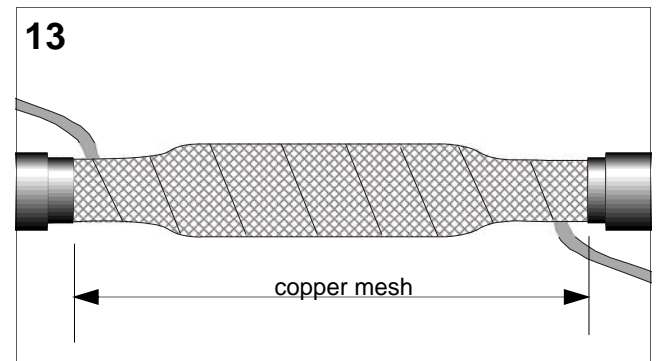

Position the first sealing sleeve over the joint sleeve area 200mm from the overshooth.
 Start shrinking in the centre working towards the ends.

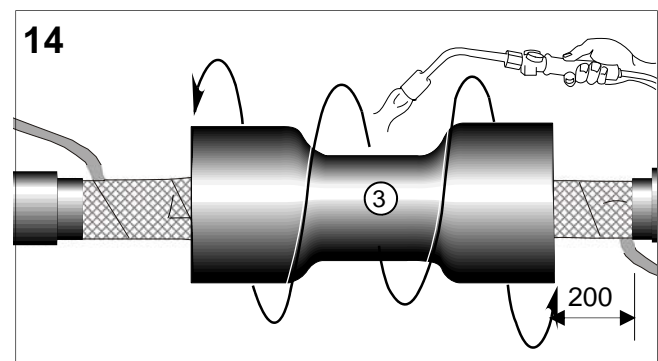

Remove the release paper from the long sealant mastic (black) and wrap one layer around the sleeve, (from Step 14) 20 mm from the end.

Clean, degrease and abrade the oversheath for a length of 150mm using the emery strip supplied in the kit.

Wrap one layer of the long sealant mastic (black) around the oversheath so that it overlaps the inner and oversheath equally.

Mark where the fibre optic will sit on the top of the mastic in step 16 above.

Wrap a layer of short black mastic around the fibre optic (approx. 80-100mm of mastic is required), directly above the mastic in step 16.

Roll up two sausages of short black mastic (50mm long) and position either side of the fibre optic, on top of the mastic as applied in step 16. Knead the mastic with your fingers to create a smooth exterior shape.

Position the second outer sealing sleeve over the joint, overlapping onto the first sleeve by 150 mm. Insert the branch clip between the cable & fibre optic. Apportioning the sleeve according to the diameters of the cable & fibre optic.

Start shrinking at the joint end, working towards the cable oversheath.

Note: Additional heat is required in the clip area to ensure the adhesive on the clip has melted, on both sides.

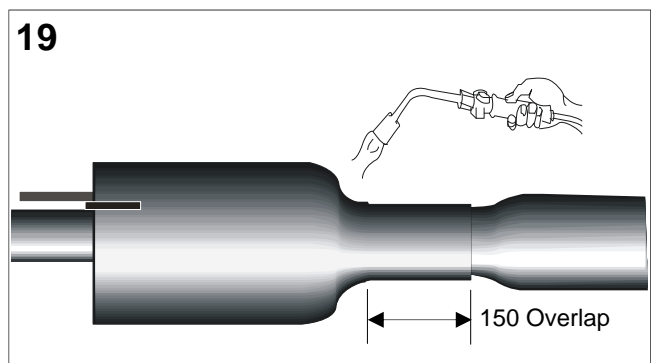
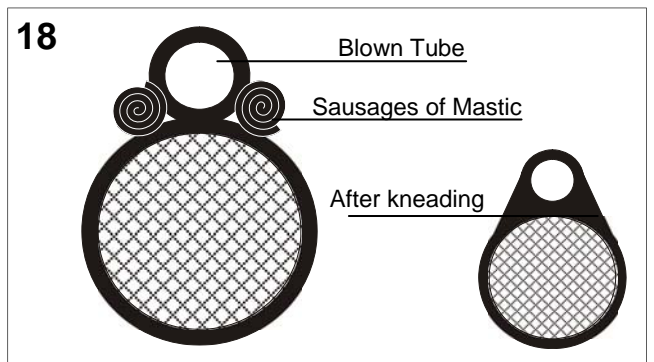
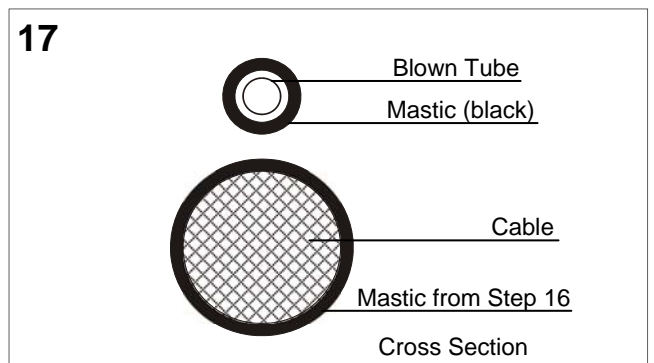
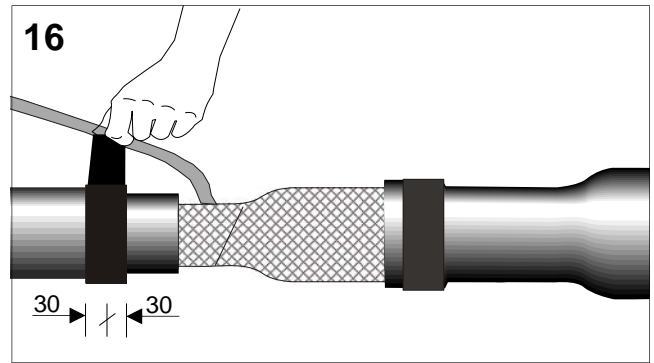
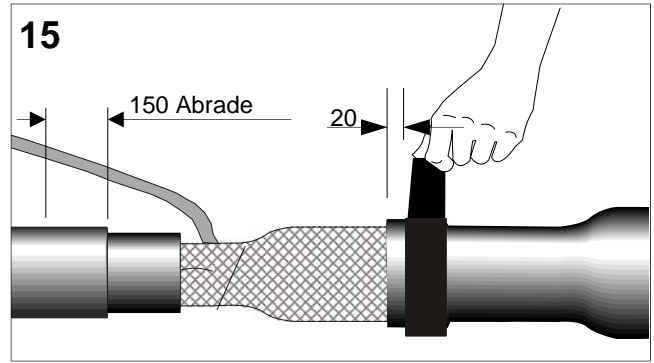

Repeat steps 15 - 19 on the other side of the joint.

Tie the fibre optic to the oversheath with a cable tie, approximately 100mm from the end of the outer sleeve.

Seal the end of each fibre element using the heatshrink end cap provided.

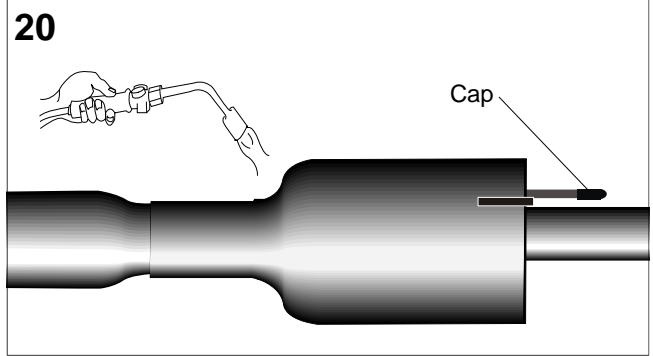

Joint completed.

Allow the joint to cool before applying any mechanical strain.

Carry out jointing of the fibre element in respective splicing enclosures to manufacturers specification.

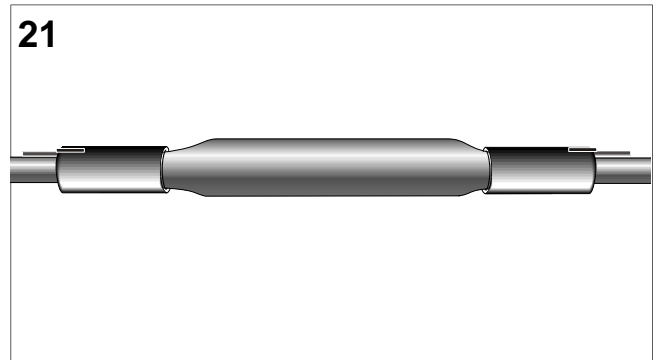

Please dispose of all waste according to environmental regulations.

